

This document is the property of Amphenol Corporation and is delivered on the express condition that it is not to be disclosed, reproduced or used, in whole or in part, for manufacture or sale by anyone other than Amphenol Corporation without its prior consent, and that no right is granted to disclose or to use any information in this document.

The marking on this product doesn't contain environmental hazardous materials per Material Specification 55-00259 for Sony GP compliant or per directive 2011/65/EU for RoHS compliant.



ORIGINAL



REVISIONS				
SYM	ECN No.	DESCRIPTION	DATE	APPROVED
A	NE-17234	RELEASE REVISION	09/05/2017	Roger Tsai
B	NE-18022	ADDED PLATING OPTION	01/25/2018	Roger Tsai
C	NE-18154	ADDED 24POS. PKG	08/01/2018	Roger Tsai

NOTES:

- MATERIAL:
 - HOUSING: HIGH TEMPERATURE THERMAL PLASTIC, NYLON 4T, UL94V-0, COLOR: OPTION.
 - CAP: HIGH TEMPERATURE THERMAL PLASTIC, LCP, UL94V-0, COLOR: BLACK.
 - TERMINAL: COPPER ALLOY.
 - FITTING NAIL: COPPER ALLOY.
- FINISH:
 - TERMINAL:
 - CONTACT AREA: SELECTIVE PLATING;
 - SOLDER AREA: GOLD FLASH PLATING;
 - UNDER PLATING: NICKEL PLATING 50u" THICKNESS MIN. OVERALL.
 - FITTING NAIL:
 - 100u" MATTE TIN PLATING OVERALL;
 - UNDER PLATING: NICKEL PLATING 50u" THICKNESS MIN. OVERALL.
- PACKING IS PER AMTA PACKING SPECIFICATION PKS-0001.
- THIS PRODUCT IS HALOGEN-FREE PRODUCT.
- PRODUCT SPECIFICATION REFER TO : PS-7623.
- RECOMMENDED MATING PART: G842AHXXT6EU/G842ACX1XT6EU.

PART NO. G846A XX 2 X 0 X T1HR

NO. OF POS.

CONTACT FINISH	COLOR
0: FULL 100u" MATTE TIN	0: NATURAL
1: GOLD FLASH	1: BLACK
2: 15u" GOLD	
3: 30u" GOLD	
4: 4u" GOLD	

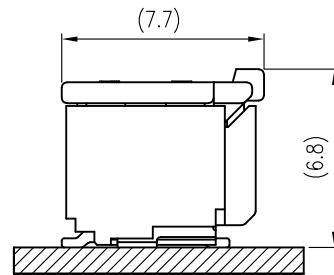
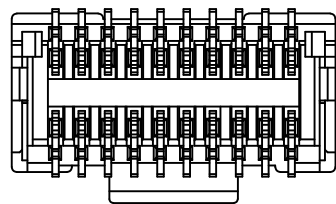
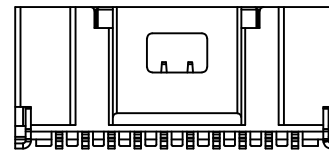
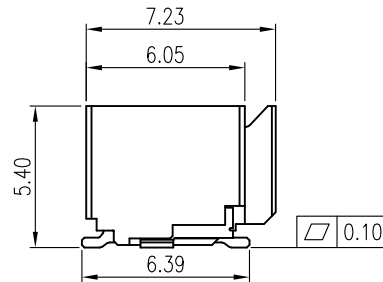
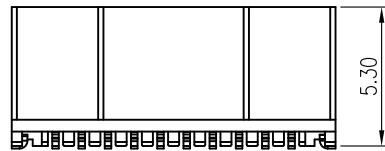
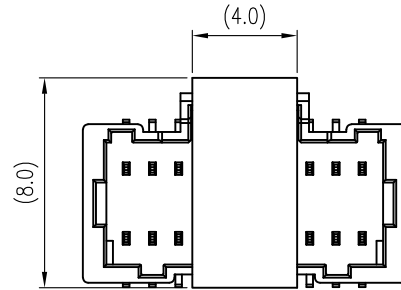
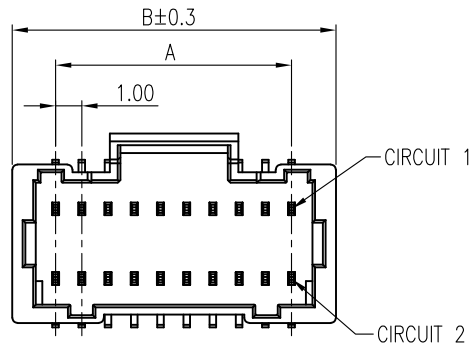

MATING CONDITION (REF.)

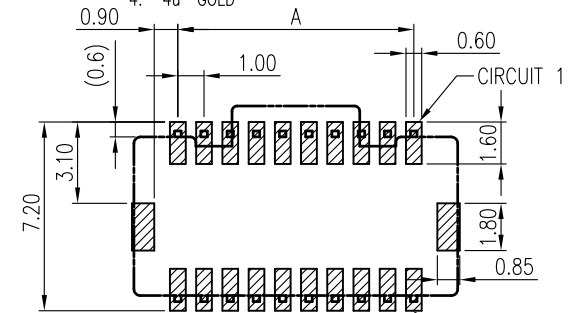

RECOMMENDED PCB LAYOUT
GENERAL TOLERANCE ±0.05

PIN	DIM.(mm)	
	A	B
2x10	9.00	12.35
2x12	11.00	14.35
2x15	14.00	17.35
2x20	19.00	22.35
2x25	24.00	27.35

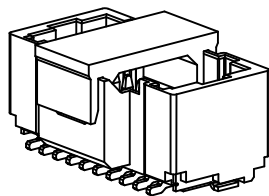

TOLERANCE		APPROVALS		DATE	TITLE		Amphenol®		
X.		DRAWN Aqua Chou		08/01/2018	G846A SERIES, WIRE TO BOARD		Amphenol Corporation		
X.X	±0.30	CHECKED Karen Su		08/01/2018	1.00 PITCH, DUAL ROWS		Amphenol Taiwan Corporation		
X.XX	±0.20	APPROVED Roger Tsai		08/01/2018	VERTICAL, SMT TYPE		PART No.	G846AXX2X0XT1HR	
X.XXX	±0.10	DWG TYPE CUST DWG		PROJECT CODE BHD	UNIT mm	SIZE A3	DWG No.		G846AXX2X0XT1HR
ANGULAR	±1°	UNLESS OTHERWISE SPECIFIED			SCALE NA	SHEET 1 OF 2	REV. C		

This document is the property of Amphenol Corporation and is delivered on the express condition that is not to be disclosed, reproduced or used, in whole or in part, for manufacture or sale by anyone other than Amphenol Corporation without its prior consent, and that no right is granted to disclose or to use any information in this document.

The marking on this product doesn't contain environmental hazardous materials per Material Specification SS-00259 for Sony GP compliant or per directive 2011/65/EU for RoHS compliant.



ORIGINAL



REVISIONS				
SYM	ECN No.	DESCRIPTION	DATE	APPROVED
A	NE-17234	RELEASE REVISION	09/05/2017	Roger Tsai
B	NE-18022	ADDED PLATING OPTION	01/25/2018	Roger Tsai
C	NE-18154	ADDED 24POS. PKG	08/01/2018	Roger Tsai

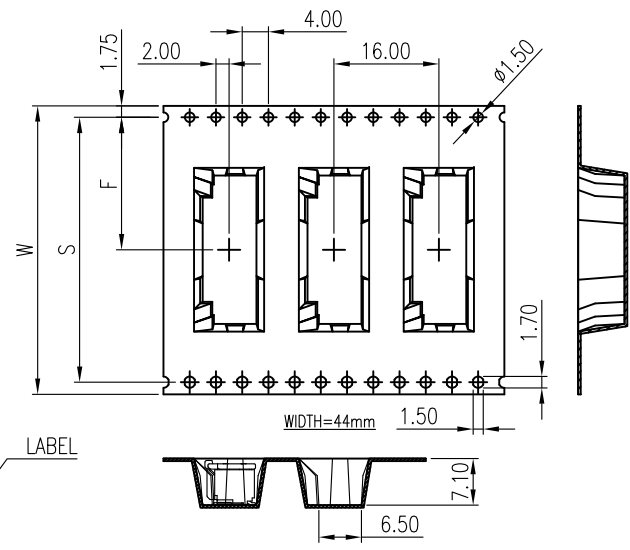
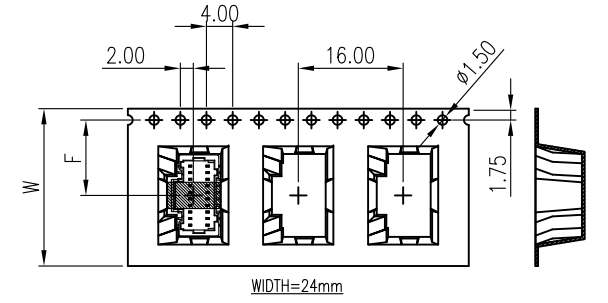
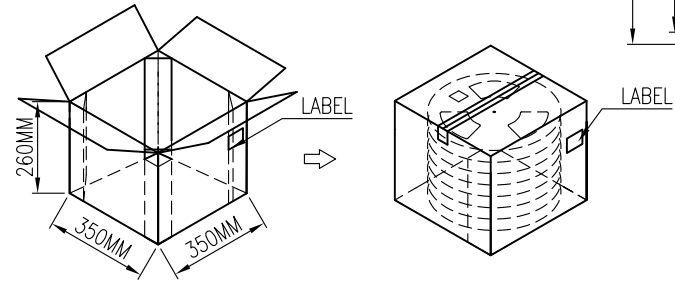
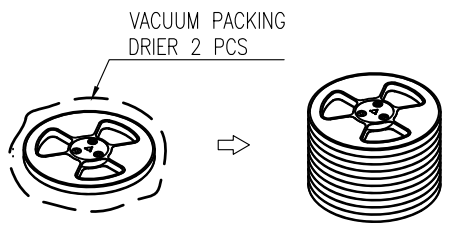
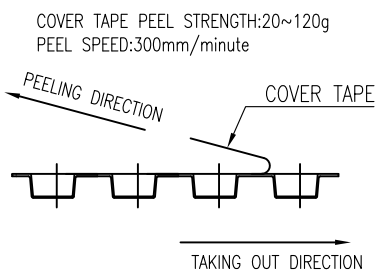
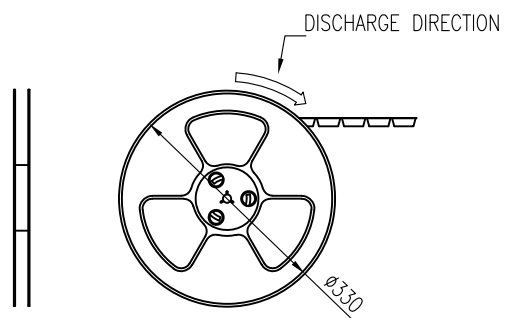
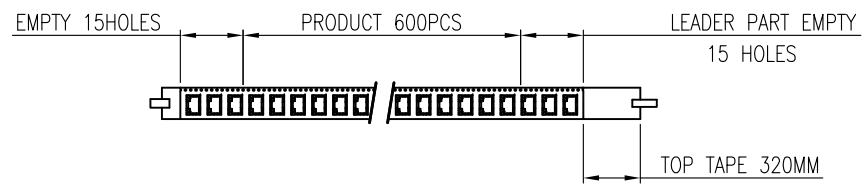

NO. OF CIRCUIT	W	S	F	REEL /PCS	CARTON /R	CARTON /PCS
2X10=20	24	/	11.50	600	8	4800
2X12=24/2X15=30	32	28.4	14.20	600	6	3600
2X20=40/2X25=50	44	40.4	20.20	600	5	3000

TOLERANCE	APPROVALS	DATE	TITLE		PART No.		
X.	DRAWN Aqua Chou	08/01/2018	G846A SERIES, WIRE TO BOARD 1.00 PITCH, VERTICAL SMT TYPE		Amphenol® Amphenol Corporation Amphenol Taiwan Corporation		
X.X ±0.30	CHECKED Karen Su	08/01/2018					
X.XX ±0.20	APPROVED Roger Tsai	08/01/2018					
X.XXX ±0.10	DWG TYPE CUST DWG	PROJECT CODE BHD	UNIT mm	SCALE NA	SIZE A3	PART No. G846AXX2X0XT1HR	
ANGULAR ±1°					SHEET 2 OF 2	DWG No. G846AXX2X0XT1HR	
UNLESS OTHERWISE SPECIFIED						REV. C	